

# Original BMW Parts and Accessories.

## Installation Instructions.

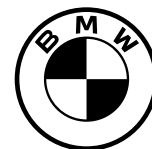

### M Performance Carbon Exterior Components Retrofit Kit.

BMW 3 Series Saloon (G20 LCI)

BMW 3 Series Touring (G21 LCI)

#### Retrofit kit number

Number	Component designation	Installation time (h)	Installation as described in ISTA/AIR*
51 19 2 455 896	Black high gloss sill add-on section, right	0.50	-
51 19 2 455 897	Black high gloss sill add-on section, left	0.50	-
51 19 5 A4B 368	Carbon right front attachment	0.40	-
51 19 5 A4B 369	Carbon left front attachment	0.40	-
51 19 2 458 369	Carbon rear spoiler	0.50	-
51 19 5 A57 B14	Carbon rear spoiler	0.50	-
51 19 2 475 051	Carbon throughflow rear spoiler	4.00	-
51 19 2 455 880	Matt black rear spoiler	0.50	-
72 15 5 A57 B31	Towing strap	0.25	-
51 19 5 A56 BD5	Black high gloss tail fins left/right**	0.50	-
51 19 5 A53 407	Carbon rear diffuser MPA***	0.10	-
51 19 5 A4F 525	Carbon rear diffuser MSP****	0.10	-
65 20 5 A59 AC9	Aramid antenna cover (see EBA 01 29 5 A5C 9E3 for installation instructions)	0.50	-
65 20 5 A59 AD9	Aramid antenna cover (see EBA 01 29 5 A5C 9E3 for installation instructions)	0.50	-
51 71 9 632 871	Carbon front ornamental grille	-	X
51 71 9 632 873	Carbon front ornamental grille	-	X
51 47 2 472 520	Sill trim, left/right	-	X
51 62 2 473 006	Black high gloss rear spoiler	-	X
51 16 2 462 824	Carbon exterior mirror covers (for MSP**** only), LHD right	-	X
51 16 2 462 825	Carbon exterior mirror covers (for MSP**** only), LHD left	-	X
51 16 2 462 826	Carbon exterior mirror covers (for MSP**** only), RHD right	-	X
51 16 2 462 827	Carbon exterior mirror covers (for MSP**** only), RHD left	-	X
51 19 5 A4F 521	Black high gloss rear bumper cover MPA***	-	X
51 19 5 A4F 522	Black high gloss rear bumper cover MSP****	-	X

\* This installation work is carried out as described in the relevant ISTA/AIR repair instructions and is not shown in these installation instructions.

\*\* The rear spoiler 51 62 2 473 006 must be installed before the tail fin 51 19 5 A56 BD5 or if the tail fin is already installed, the rear spoiler cannot be installed.

\* MPA = M Performance Automobile

\*\*\*\* MSP = M Sport package

#### Installation time

Installation time, see table. This may vary depending on the condition of the vehicle and the equipment in it.

The installation time shown does not include any time spent on programming/coding.

The calculation of the total costs for the programming time must be factored into the calculation of retrofitting costs (must not be invoiced under the warranty).

### **Important information**

These installation instructions are primarily designed for use within the BMW dealership organisation and by authorised BMW service companies.

These installation instructions are intended for use by qualified specialist staff trained on BMW cars with the relevant expert knowledge.

All work must be completed using the latest BMW repair manuals, wiring diagrams, servicing manuals and work instructions, in a logical order, using the prescribed tools (special tools), and observing current health and safety regulations.

After the installation of the carbon rear diffuser retrofit set, it must be programmed/coded via the – **Retrofits** – path.

### **The front attachment may only be installed with the standard gurney flap (MPA cars) or M Performance Carbon rear spoilers.**

The installation constraints for the rear spoilers are set out in the EPC (electronic parts catalogue).

### **If you experience installation or functional problems, restrict troubleshooting to approx. 0.5 hours for mechanical work and 1.0 hour for electrical work.**

To avoid unnecessary extra work and/or costs, send an inquiry to the technical parts support team.

Quote the following information:

- VIN,
- retrofit kit part number,
- a detailed description of the problem,
- any work already carried out.

Do not archive the printout of these installation instructions. The current version can be found in the EPC (electronic parts catalogue).

### **Pictograms**

 Denotes instructions that draw your attention to dangers.

 Denotes instructions that draw your attention to special features.

◀ Denotes the end of the instruction or other text.

### **Installation information**

- All contact/bonding surfaces on the components being installed must be absolutely dry, clean, and free of wax, silicone and grease. These surfaces must be treated with a suitable BMW cleaner or BMW primer (see EPC for details), using the appropriate product application instructions.
- If you use adhesive tape, it must be applied using a contact pressure of between 10 N/cm<sup>2</sup> and 50 N/cm<sup>2</sup>.
- Take care not to damage the parts when opening the packaging.
- Check that all the parts fit accurately on the car before installing them.
- All the components and their bonding surfaces must be at room temperature for installation. The ideal relative humidity is 50%. Different values will change the specified times.
- After completing the bonding and installation work, the car must remain stationary at room temperature for at least 12 hours.

- If liquid adhesives are used, the car may be driven after 24 hours, and may be taken through a car wash after 48 hours. The car may only be driven at a speed of  $v_{\max} < 100$  km/h for a period of 24 to 48 hours.
- The installed parts may become loose and fly off the car if you fail to wait for the full reaction time of the primer/liquid adhesive. Danger of accidents!
- Some of the installation steps are shown only on one side of the car. Proceed in the same way on the other side of the car.
- All illustrations show LHD cars; proceed in the same way on RHD cars.

**Special tools required**

- None

## Table of contents

Section	Page
1. Carbon front attachment parts list .....	5
2. Carbon rear spoiler parts list .....	6
3. Matt black rear spoiler parts list .....	7
4. Carbon throughflow rear spoiler parts list .....	8
5. Black high gloss side sill add-on section parts list .....	9
6. Carbon rear diffuser and black high gloss rear bumper trim parts list .....	10
7. Black high gloss tail fin parts list .....	11
8. Towing strap parts list .....	12
9. Preparatory work .....	13
10. Carbon front attachment installation .....	14
11. Carbon rear spoiler installation .....	17
12. Matt black rear spoiler installation .....	19
13. Carbon throughflow rear spoiler installation .....	21
14. Black high gloss side sill add-on section installation .....	27
15. Carbon rear diffuser installation .....	29
16. Black high gloss tail fin installation .....	30
17. Towing strap installation .....	32
18. Concluding work and coding .....	34

## 1. Carbon front attachment parts list

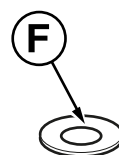
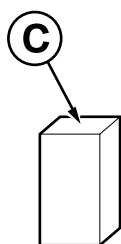
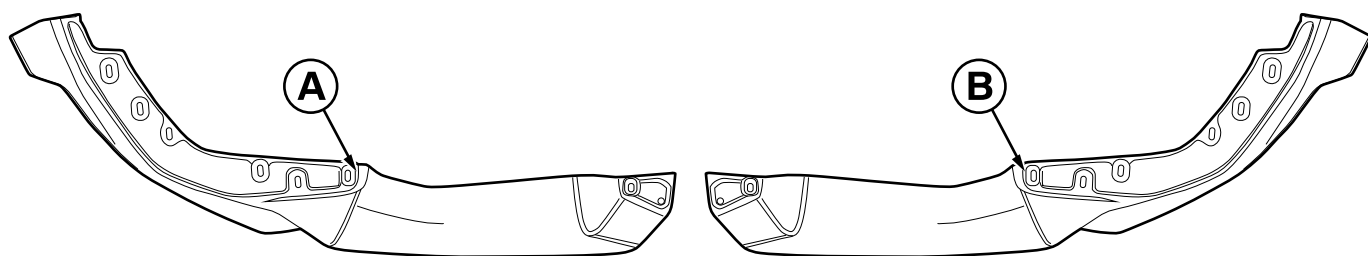

G20 0158 V

### Legend

- A** Carbon right front attachment
- B** Carbon left front attachment
- C** Liquid adhesive (not included in kit, see EPC for details)
- D** Cleaner (not included in kit, see EPC for details)
- E** Screw (2 x, not included in the parts kit, see EPC)
- F** Washer (2 x, not included in the parts kit, see EPC)
- G** Nut (2 x, not included in the parts kit, see EPC)

## 2. Carbon rear spoiler parts list

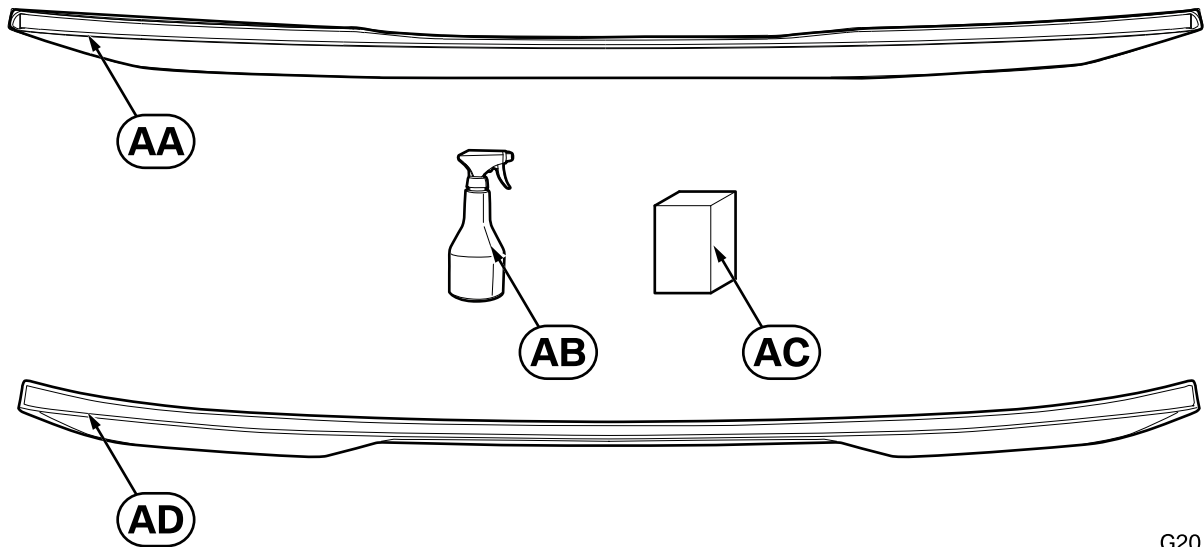

G20 0180 V

### Legend

- AA** Carbon rear spoiler (Part No. 51 19 2 458 369)
- AB** Cleaner (not included in kit, see EPC for details)
- AC** Liquid adhesive (not included in kit, see EPC for details)
- AD** Carbon rear spoiler (Part No. 51 19 5 A57 B14)

### 3. Matt black rear spoiler parts list

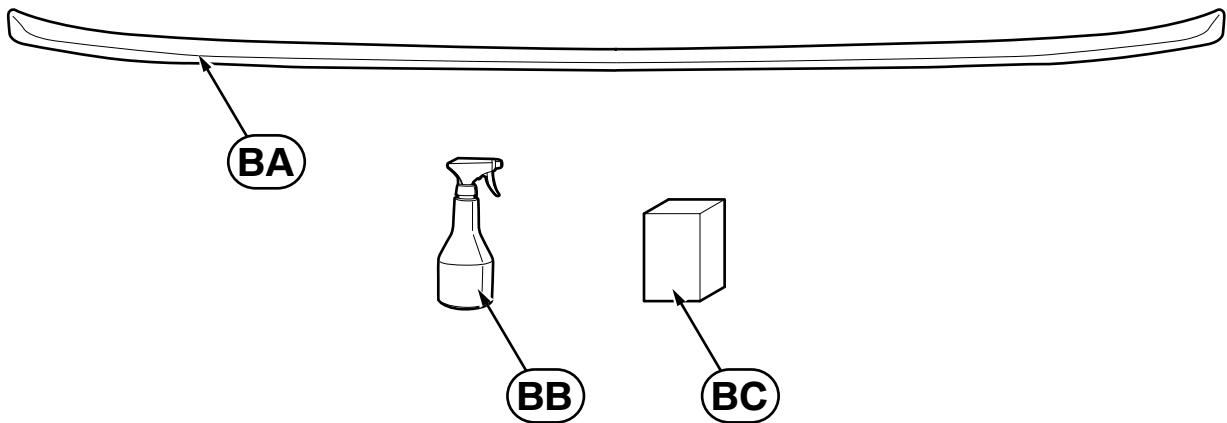

G20 0034 V

#### Legend

- BA** Matt black rear spoiler
- BB** Cleaner (not included in kit, see EPC for details)
- BC** Liquid adhesive (not included in kit, see EPC for details)

## 4. Carbon throughflow rear spoiler parts list

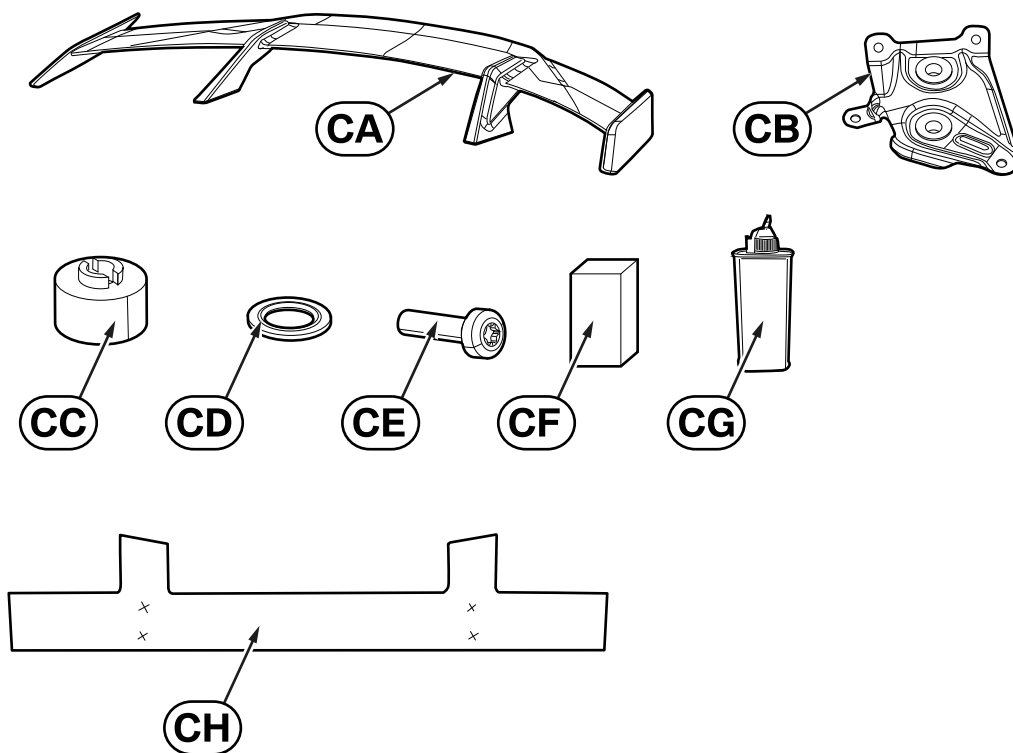

G20 0190 V

### Legend

- CA** Carbon throughflow rear spoiler
- CB** Holder plate, left/right G20/G80 (2 x, left side shown)
- CC** Adjustment sleeve (4 x)
- CD** Sealing ring (4 x, see EPC for details)
- CE** Pan-head screw M6x25 (4 x, see EPC for details)
- CF** Liquid adhesive (not included in kit, see EPC for details)
- CG** Cleaner R2 (not included in kit, see EPC for details)
- CH** Boot lid spoiler drilling template (included in parts kit)

## 5. Black high gloss side sill add-on section parts list

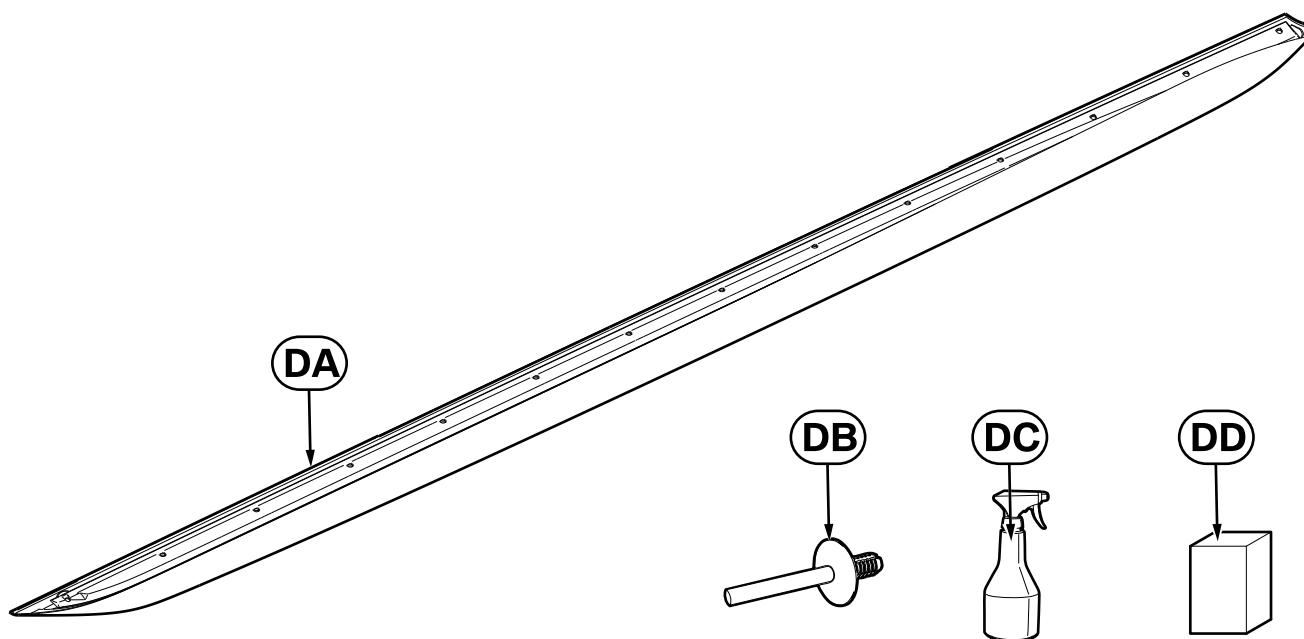

G20 0044 V

### Legend

- DA** Black high gloss sill add-on section, left/right (2 x, left side shown)
- DB** Rivet (14 x per side)
- DC** Cleaner (not included in kit, see EPC for details)
- DD** Liquid adhesive (not included in kit, see EPC for details)

## 6. Carbon rear diffuser and black high gloss rear bumper trim parts list

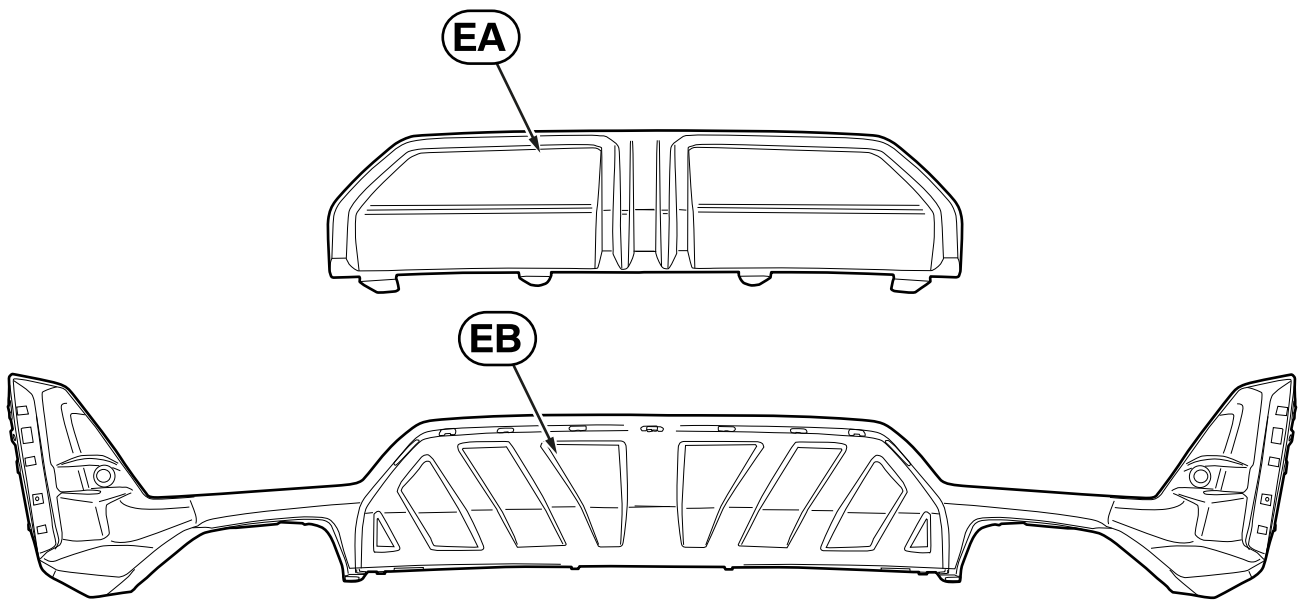

G20 0178 V

### Legend

- EA** Carbon rear diffuser (MPA shown)
- EB** Black high gloss rear bumper cover (MPA shown)

## 7. Black high gloss tail fin parts list

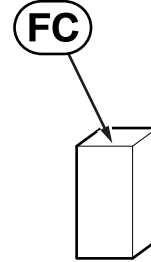
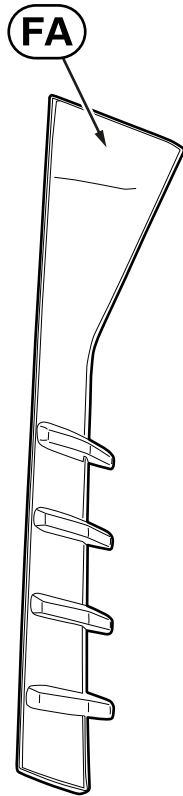

G21 0018 V

### Legend

- FA** Black high gloss tail fin, left/right (2 x, left side shown)
- FB** Cleaner R1 (not included in kit, see EPC for details)
- FC** Liquid adhesive (not included in kit, see EPC for details)
- FD** Primer (not included in kit, see EPC for details)

## 8. Towing strap parts list

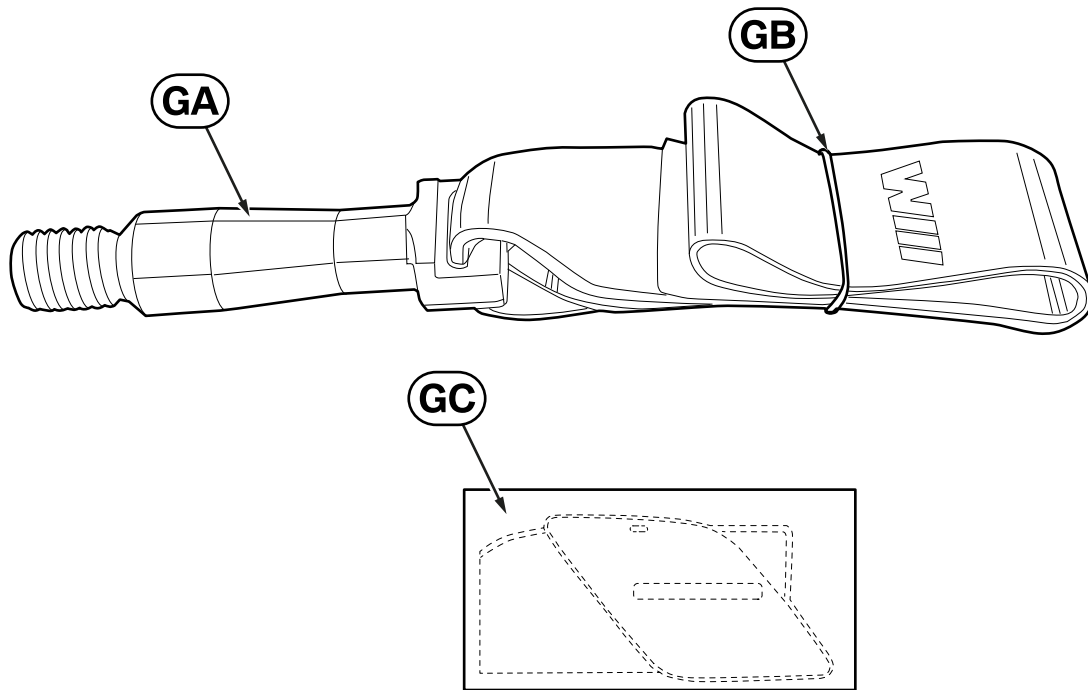

G20 0170 V

### Legend

- GA** Towing strap
- GB** Rubber ring
- GC** Template, front/rear

## 9. Preparatory work

	ISTA/AIR No.
<b>The following components must be removed first of all</b>	
<b>For installing the rear spoiler only</b>	---
– The standard rear spoiler may already be installed	
– Standard rear bumper trim	

## 10. Carbon front attachment installation

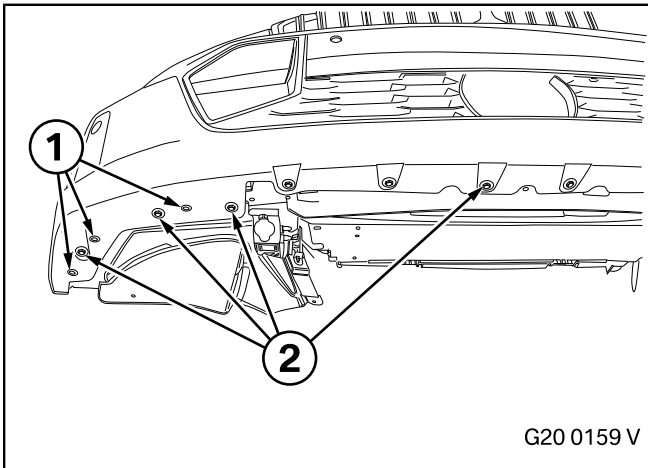

Remove the three expanding rivets (1) and four screws (2) on both sides.

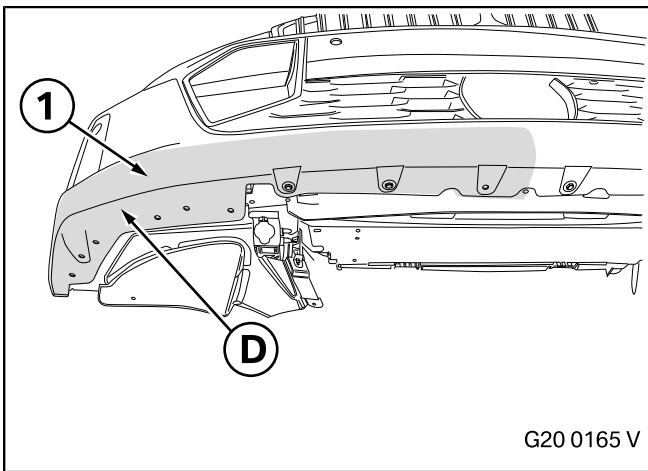

▶ The bonding surfaces must be completely dry, clean, and free from wax or grease. ◀

Clean the two surfaces (1) of the car with cleaner **D**.

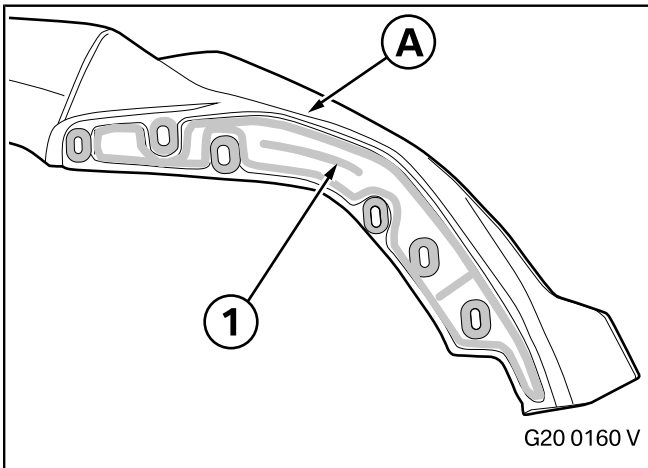

▶ To show it more clearly, the carbon right front attachment **A** is shown in two graphics. ◀

Abrade the surfaces marked in grey (1) with suitable products.

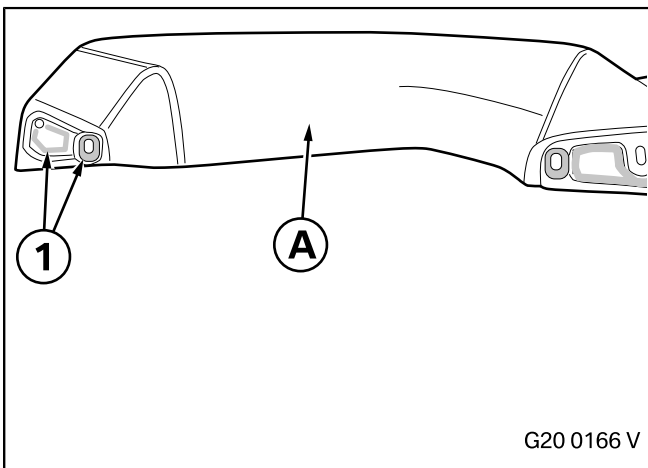

Abrade the surfaces (1) with suitable products.

Clean all the surfaces you have abraded with cleaner **D**.

## 10. Carbon front attachment installation

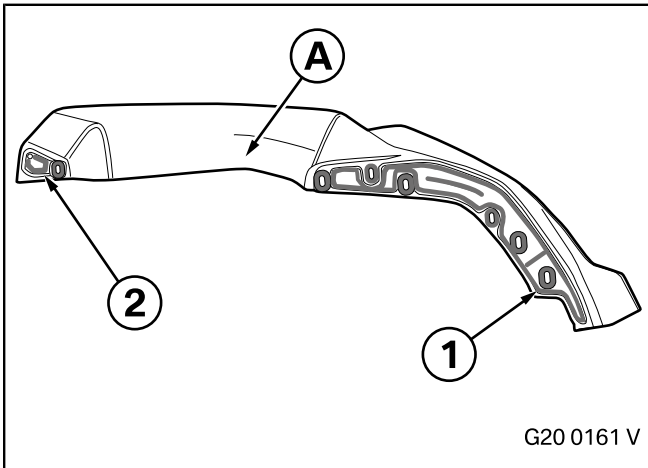

Apply a thin coating of liquid adhesive along the marks shown (1) and (2).

Ensure that you keep a gap of **around 5 mm** from the front edge so that the liquid adhesive does not escape into the visible area.

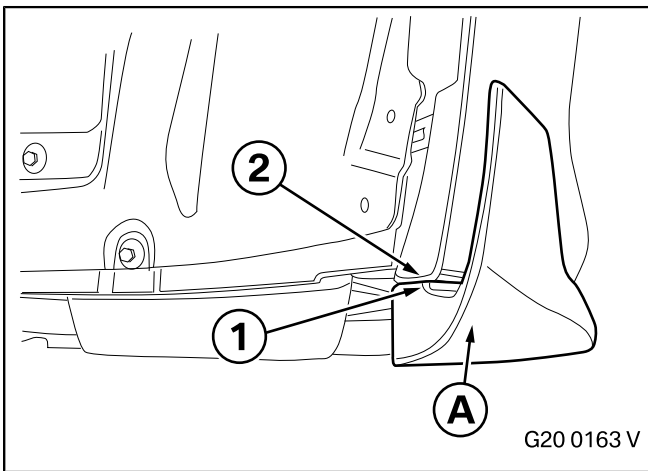

▶ This work should be completed by two people. ◀

Position the carbon right front attachment **A** starting from the outside. Check the contour (1), it must finish flush with the wheel arch trim (2).

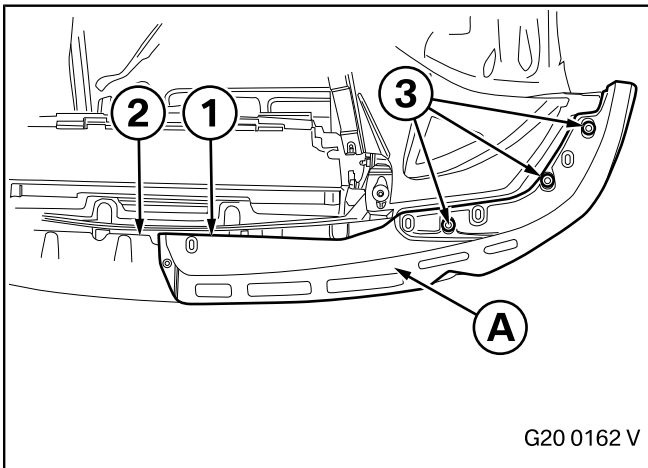

Towards the centre, the edge (1) of the carbon right front attachment **A** must finish flush with the edge of the front apron (2).

Press in the three expanding rivets (3).

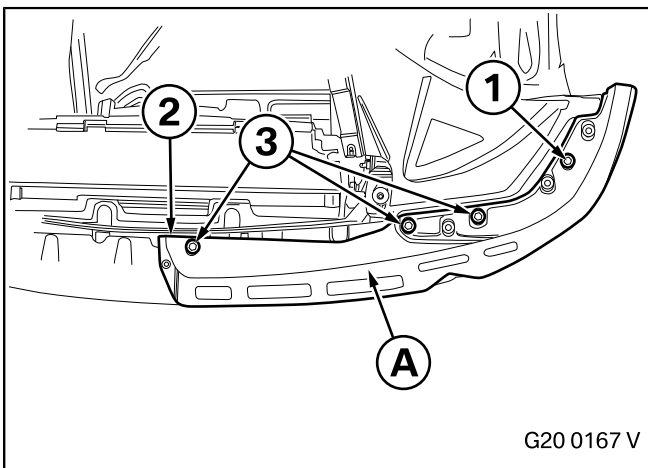

Screw in the outer screw (1) loosely only.

Check the position (2) of the carbon right front attachment **A** and then tighten the three other screws (3). Also tighten screw (1).

## 10. Carbon front attachment installation

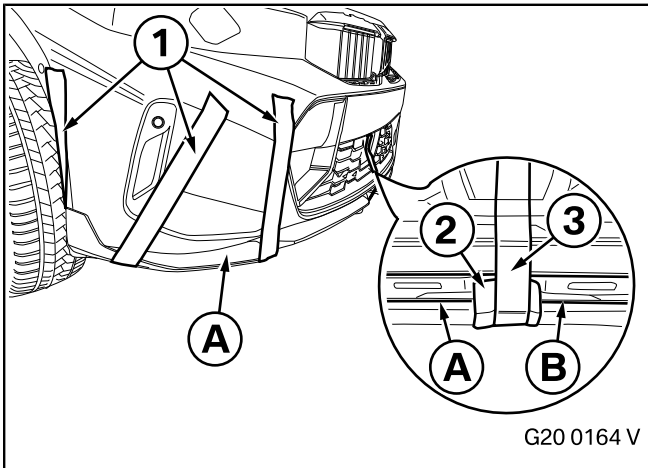

Secure the carbon right front attachment **A** at several points using suitable adhesive tape (1).

Repeat the installation work on the left side of the car for the carbon left front attachment **B**.

Then protect the two central ends of the carbon front attachments **A** and **B** using a suitable object (2) and apply adhesive tape (3) to secure it.

▶ Leave the car to stand for 12 hours. ◀

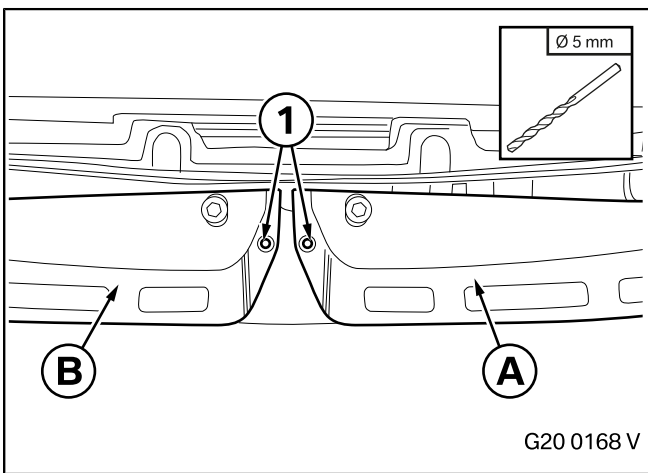

▶ When drilling holes, pay attention to the package base behind where you are drilling. ◀

Drill holes (1) with a diameter of **5 mm** from the outside through the carbon right front attachment **A** and carbon left front attachment **B** through the front apron.

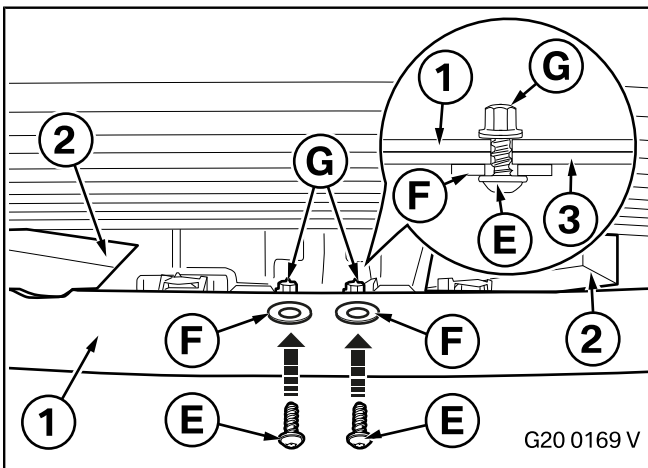

Bend up the front apron (1) from the inside and open the gap using suitable objects (2) so that you can position the nuts **G**.

Position the washers **F** on the holes in the carbon front attachment (3) and tighten the screws **E** from the outside through the installation holes.

Remove the objects (2).

▶ Leave the car to stand for a further 12 hours and refer to the instructions on page 2. ◀

## 11. Carbon rear spoiler installation

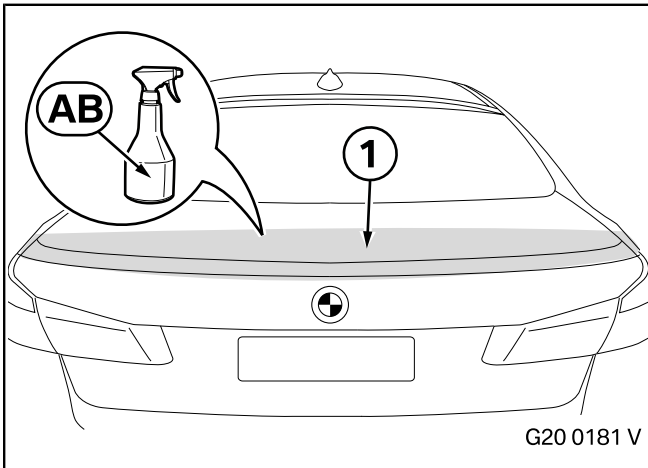

- ▶ The installation work is shown for the carbon rear spoiler **AA** (Part No. **51 19 2 458 369**). Use the same installation procedure for the carbon rear spoiler **AD** (Part No. **51 19 5 A57 B14**).

The bonding surfaces must be completely dry, clean, and free from wax or grease. ◀

Clean the surface (1) of the car with cleaner **AB**.

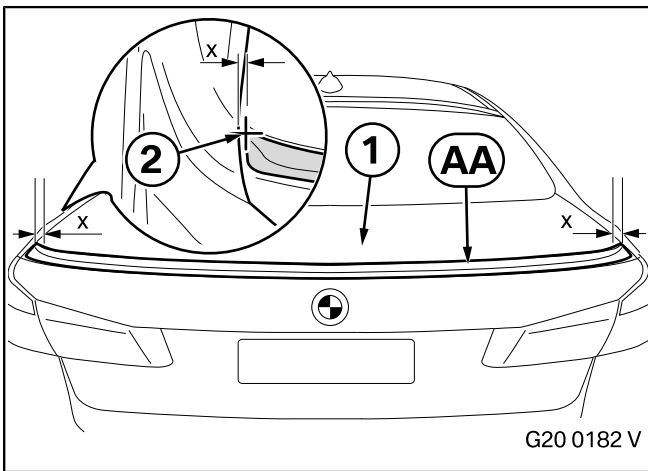

Position the carbon rear spoiler **AA** on the boot lid (1), centre it and mark the position (2) with suitable products.

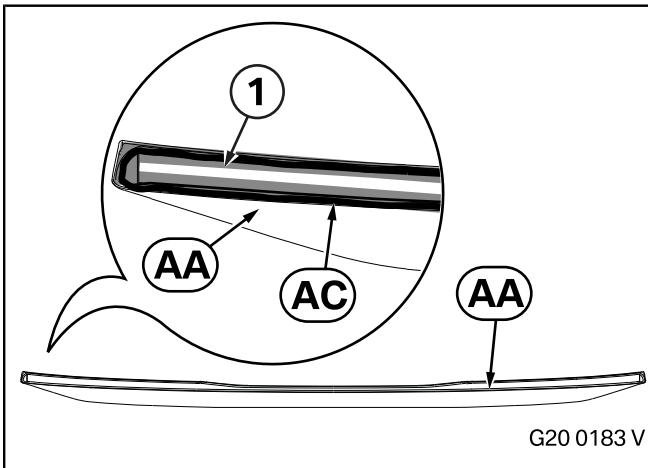

Abrade and clean the edge area (1) of the carbon rear spoiler **AA** using suitable products.

Apply an adequate quantity of liquid adhesive **AC**, as shown, in the form of a bead, **generously** to the carbon rear spoiler **AA**.

## 11. Carbon rear spoiler installation

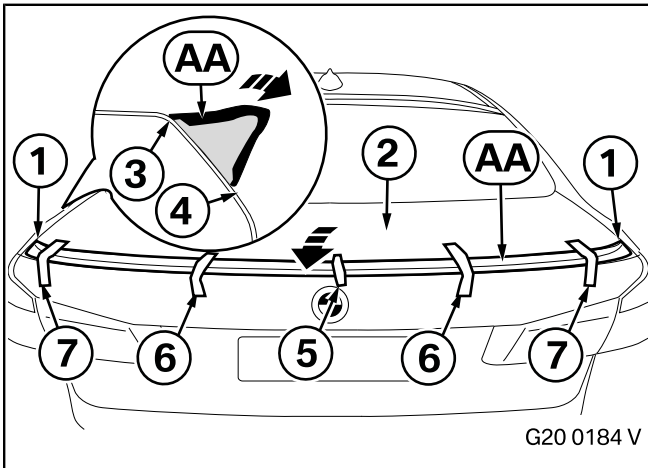

▶ Remove any excess liquid adhesive **AC** immediately. ◀

Position the carbon rear spoiler **AA** between the marks (1) and align it.

Pull the centre of the carbon rear spoiler **AA** to the rear in the direction shown by the arrow without touching the boot lid (2) until the front gap (3) has closed. Then press the carbon rear spoiler **AA** onto the boot lid (2) so that the bottom gap (4) closes.

Secure the carbon rear spoiler **AA** first in the centre with adhesive tape (5) and then towards the outside with adhesive tapes (6) and (7). Do not remove the adhesive tapes (5), (6) and (7) for at least 6 hours.

▶ Leave the car to stand for 24 hours and refer to the instructions on page 2. ◀

## 12. Matt black rear spoiler installation

### Painting instructions

Check that all the kit components fit accurately on the car before painting them. Primed kit components must be pre-treated appropriately before painting.

Follow the BMW painting instructions (see **ISTA/AIR No. 99 00 ...**).

▶ The matt black rear spoiler **BA** can be partially painted as required by the customer. ◀

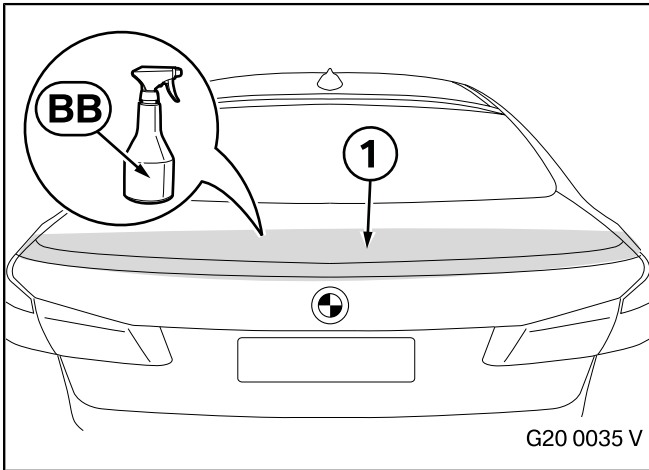

▶ The bonding surfaces must be completely dry, clean, and free from wax or grease. ◀

Clean the surface (1) of the car with cleaner **BB**.

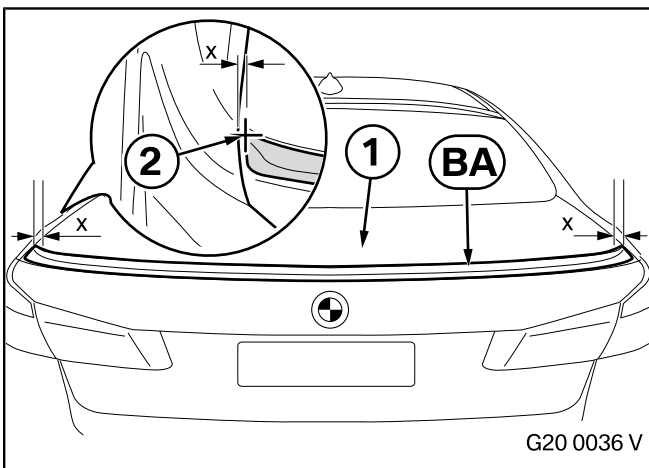

Position the matt black rear spoiler **BA** on the boot lid (1), centre it and mark the position (2) using suitable tools.

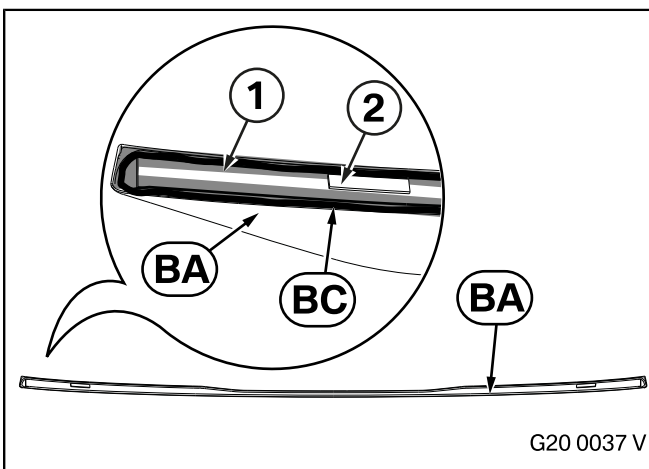

Abrade and clean the edge area (1) of the matt black rear spoiler **BA** using suitable products.

Apply an adequate quantity of liquid adhesive **BC**, as shown, in the form of a bead, **generously** to the matt black rear spoiler **BA**.

Remove backing film (2).

## 12. Matt black rear spoiler installation

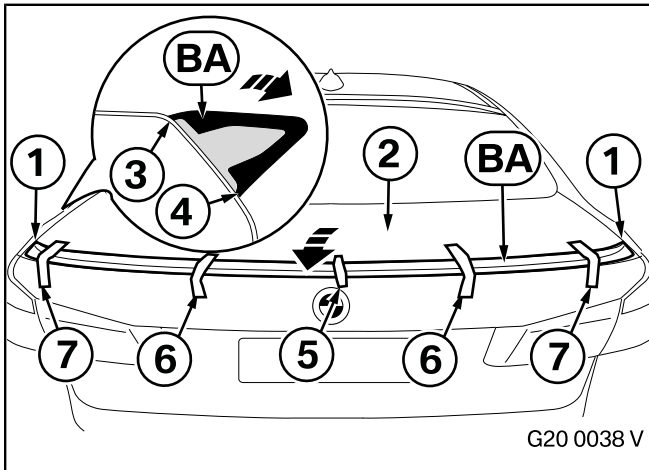

▶ Remove any excess liquid adhesive **BC** immediately. ◀

Position the matt black rear spoiler **BA** between the marks (1) and align it.

Pull the centre of the matt black rear spoiler **BA** to the rear in the direction shown by the arrow without touching the boot lid (2) until the front gap (3) has closed. Then press the matt black rear spoiler **BA** onto the boot lid (2) so that the bottom gap (4) also closes.

Secure the matt black rear spoiler **BA** first in the centre with adhesive tape (5) and then with the outer adhesive tapes (6) and (7).

The adhesive tapes (5), (6) and (7) cannot be removed for at least 6 hours.

▶ Leave the car to stand for 24 hours and refer to the instructions on page 2. ◀

### 13. Carbon throughflow rear spoiler installation

- The carbon throughflow rear spoiler can be installed with the boot lid either installed or removed. If the boot lid is removed, the installation times are higher than those stated.
- First of all, the internal trim on the boot lid must be removed.
- Spread a sheet to collect any chips. Ensure that no chips fall into the boot lid.
- Use suitable suction equipment to remove the chips from each hole during and after the drilling work.
- Use a new drill bit. There is a risk of forming dents if you apply excessive force when using blunt drill bits.
- Use a high speed and low pressure for drilling the holes.
- Treat all the drilled holes with anti-corrosive primer or suitable products.

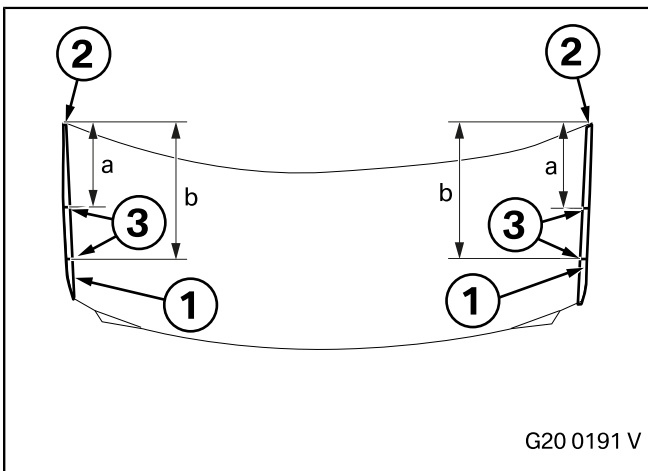

▶ **As a result of production tolerances in the boot lid, you must measure the precise centre of the boot lid.**

The bonding surface must be completely clean, dry and free from wax or grease. ◀

Apply suitable adhesive tape (1) to the outside edges of the boot lid.

From the edge (2), measure **a = 190 mm** and apply a mark (3) to the adhesive tape.

From the edge (2), measure **b = 315 mm** and apply a mark (3) to the adhesive tape.

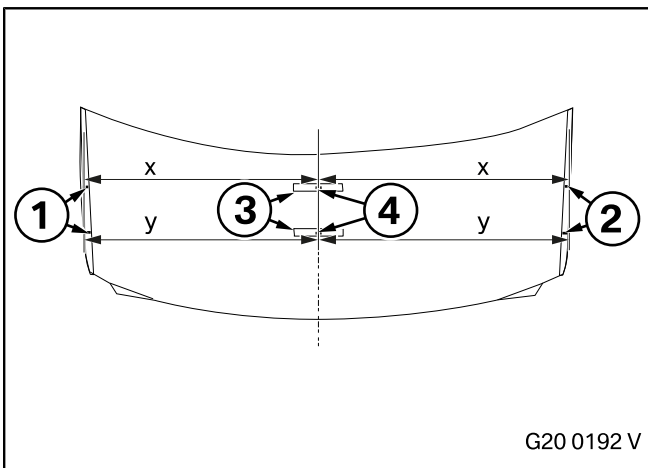

Place a measuring tape between mark (1) and mark (2) and bond a piece of adhesive tape (3) at the centre of the boot lid level with the marks. Then find the exact centre of the boot lid between marks (1) and (2) and apply two marks (4) to the two pieces of adhesive tape (3).

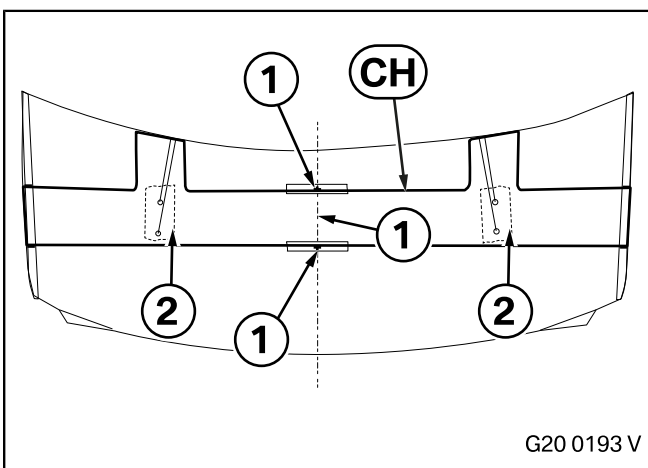

Position the boot lid spoiler drilling template **CH** in the centre using the marks (1).

Bond a suitable piece of adhesive tape (2) the boot lid near the drilling points on the boot lid spoiler drilling template **CH**.

### 13. Carbon throughflow rear spoiler installation

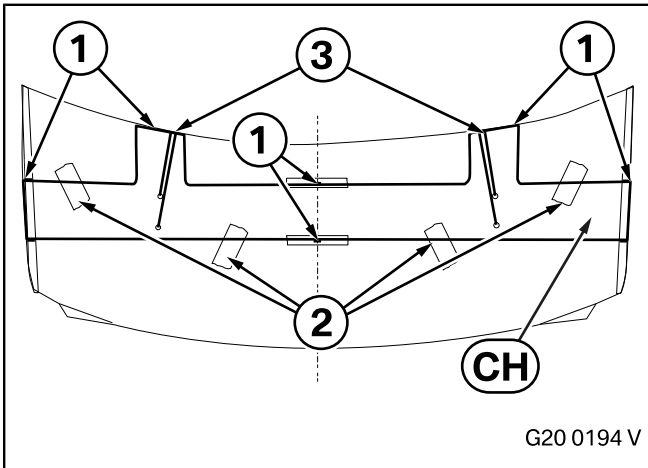

▶ **The control distances must be equal on both sides.** ◀

The boot lid spoiler drilling template **CH** must be flush at the edges (1).

Secure it using suitable adhesive tape (2).

Check the control dimensions (3) on the boot lid spoiler drilling template **CH**. If necessary, remove the adhesive tapes (2) and correct the position of the boot lid spoiler drilling template **CH**.

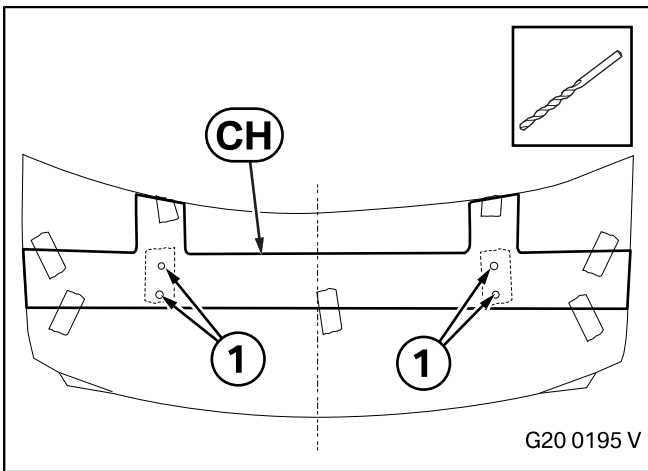

▶ **You must carry out control measurements and make sure the positions are symmetrical. Make sure that your work is accurate as the holes will determine the later position of the carbon throughflow rear spoiler.** ◀

Predrill the holes (1) through the template with a **3 mm** drill bit perpendicular to the external skin.

Then drill them with a **6 mm** drill bit through the external and internal metal of the boot lid extracting the chips as you do so.

Remove all the chips which are still on and in the boot lid and remove the drilling template **CH** and adhesive tapes.

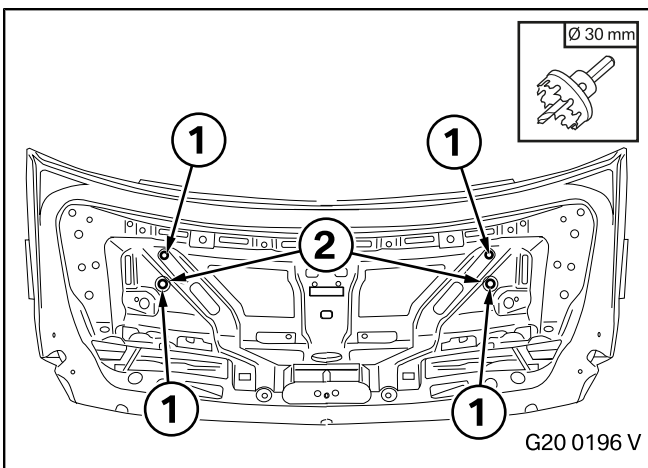

▶ **Do not drill through the external skin.** ◀

Carefully enlarge the four holes (1) in the inside plate of the boot lid using a keyhole saw  $\varnothing = 30 \text{ mm}$  with an inserted centring drill bit  $\varnothing = 6 \text{ mm}$  and deburr it using suitable equipment.

After this, two adhesive tapes (2) will be visible and must be removed using suitable equipment.

### 13. Carbon throughflow rear spoiler installation

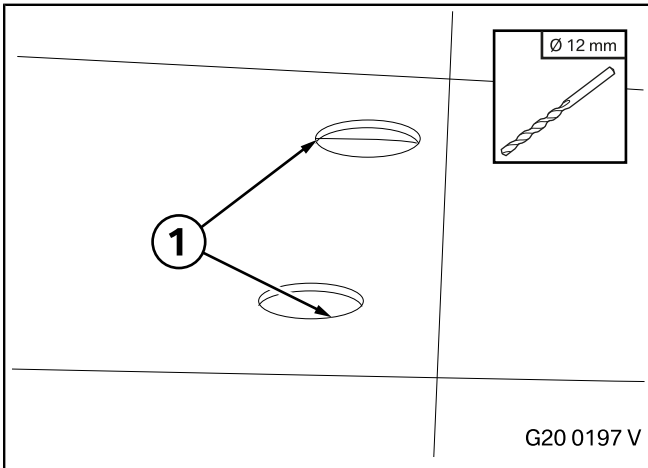

Enlarge the hole (1) on the external skin of the boot lid. To do so, enlarge it in stages to  $\varnothing = 8 \text{ mm}$ ,  $\varnothing = 10 \text{ mm}$  and then to  $\varnothing = 12 \text{ mm}$ .

Deburr the edges. Seal the edges with cavity sealant and leave it to dry for the time stated in the instructions for use.

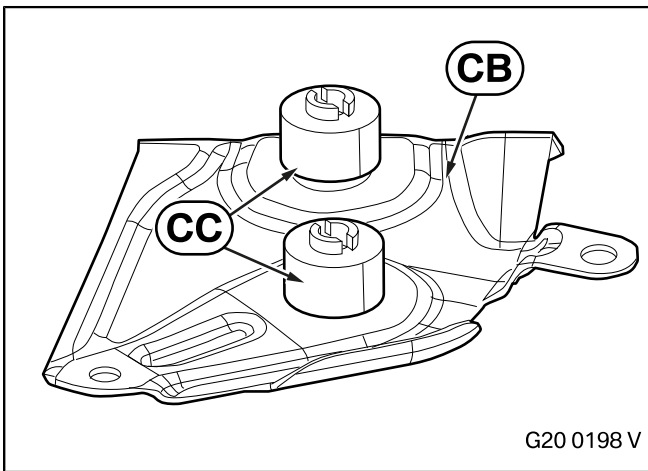

Screw the adjusting sleeves **CC** fully onto the holder plates **CB**.

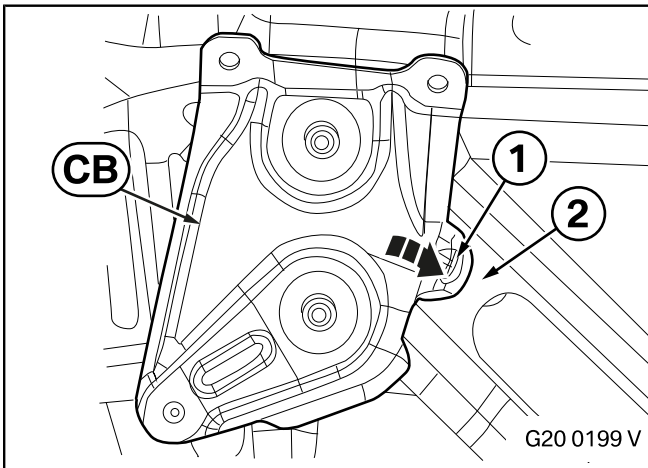

Position the lugs (1) on the holder plates **CB** behind the cut-outs (2).

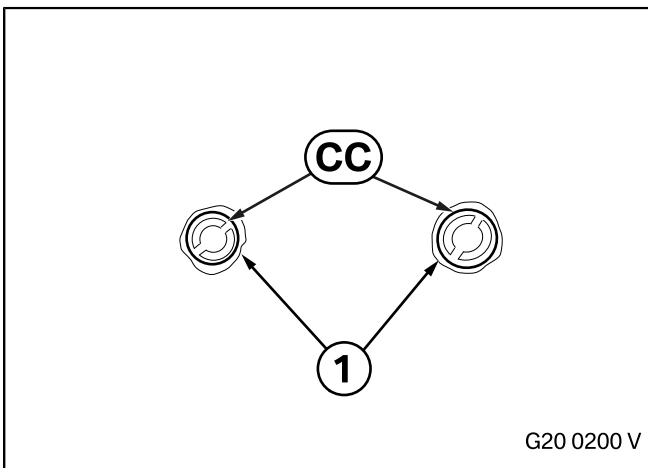

 The head on the adjustment sleeve **CC** must be **flush** with the external skin (1) of the rear spoiler. ◀

Adjust the adjustment sleeves **CC** on the outside using a flat screwdriver with a blade width of 10 mm until the head of the adjustment sleeve **CC** is flush with the external skin (1) the rear spoiler.

### 13. Carbon throughflow rear spoiler installation

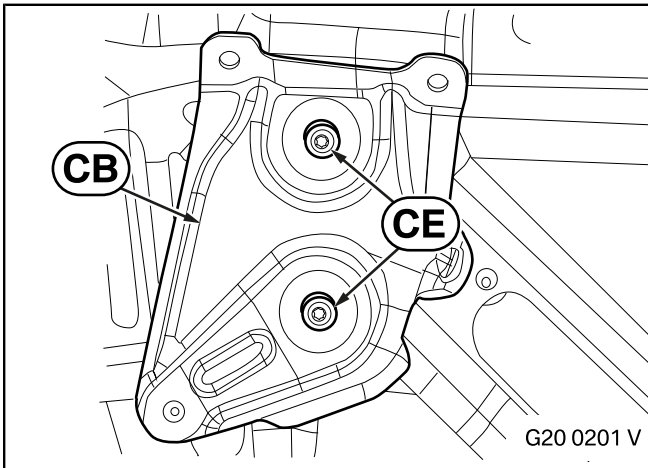

⏏ This installation step must be carried out by three people. ◀

Position the boot lid rear spoiler **CA** from the outside with two people and from the inside secure the holder plates **CB** to the boot lid using the four screws M6x25 **CE**.

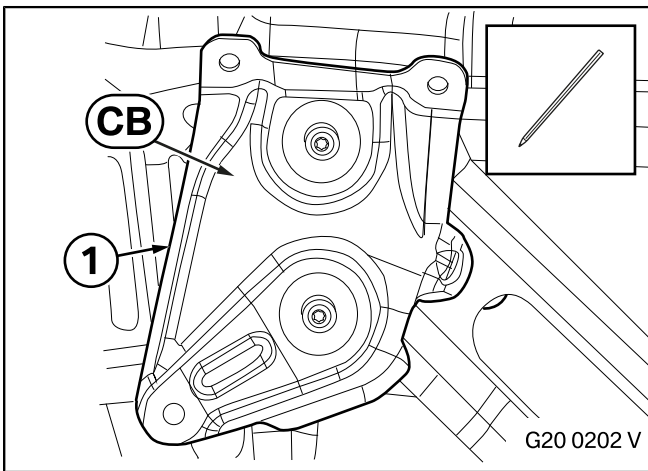

Transfer the contour (1) of the holder plates **CB** to the boot lid.

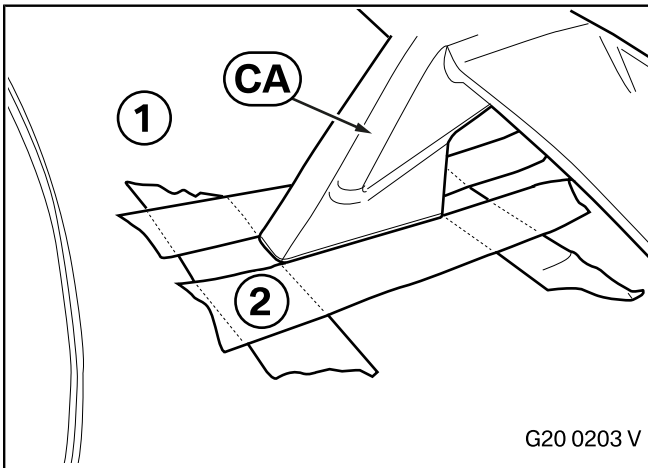

Mask the boot lid (1) using suitable adhesive tape (2) around the fixings for the boot lid spoiler **CA** so that the residues of the liquid adhesive can be removed more easily later. Position the adhesive tape (2) so that it is around **1 mm** from the boot lid spoiler **CA**.

Remove the holder plates **CB** and boot lid spoiler **CA** by undoing the screws **CE**.

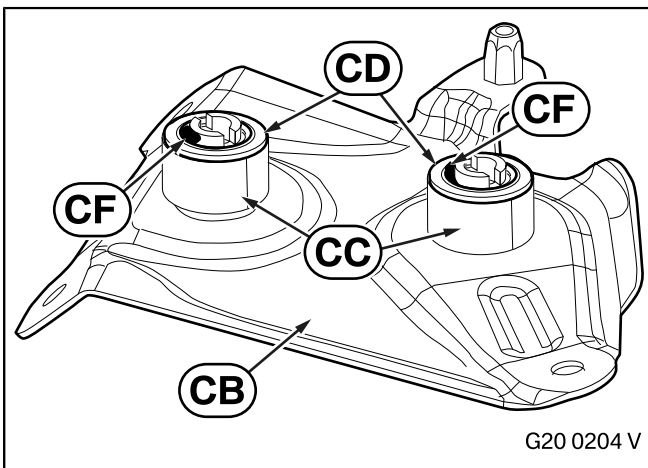

Pull the sealing rings **CD** onto the adjustment sleeves **CC** which are installed on the holder plates **CB**.

⏏ Secure the sealing rings **CD** with liquid adhesive **CF** or suitable equipment as they may fall out without you noticing during the installation process. ◀

### 13. Carbon throughflow rear spoiler installation

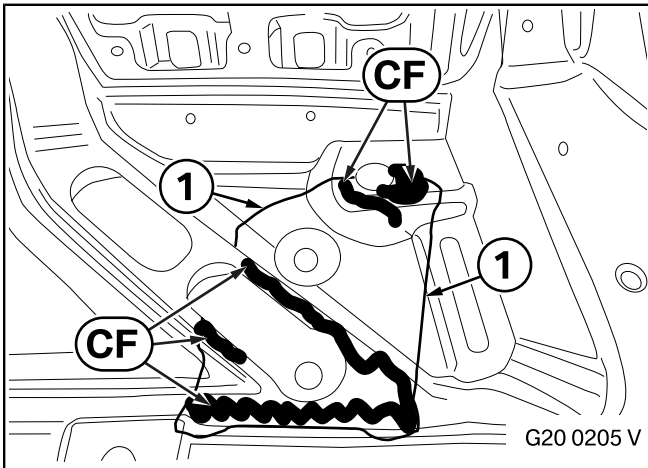

Apply a bead of liquid adhesive **CF** to the boot lid inside the marked contour (1).

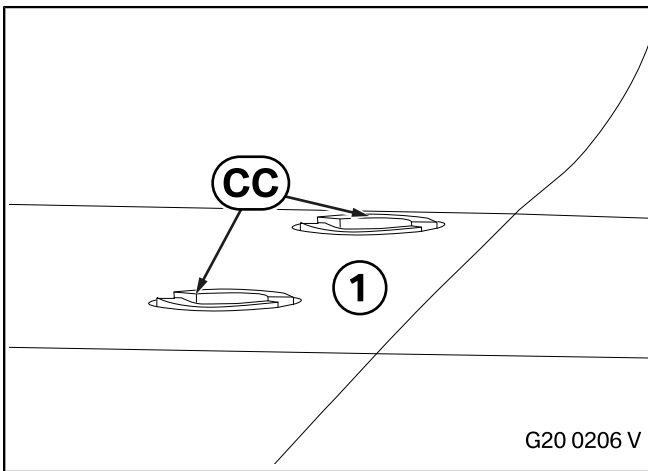

It is important to ensure that the throughflow rear spoiler is flush on the metal and on the adjustment sleeves **CC**. If the adjustment sleeves **CC** are too high, they will cause a gap between the metal and the rear spoiler. If the adjustment sleeves **CC** are too low, they will cause deformation on the metal. ◀

Adjust the adjustment sleeves **CC** from outside. Unscrew them until the head is **flush** with the external skin of the boot lid.

As you unscrew them, ensure that you do not damage the boot lid. ◀

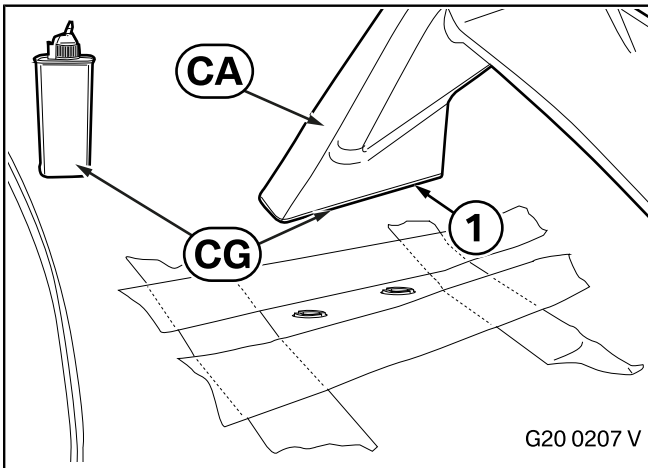

Sand the surface (1) of the rear spoiler **CA** with suitable products.

Then clean the surface (1) with cleaner **CG**.

Wait for the drying time of the cleaner. ◀

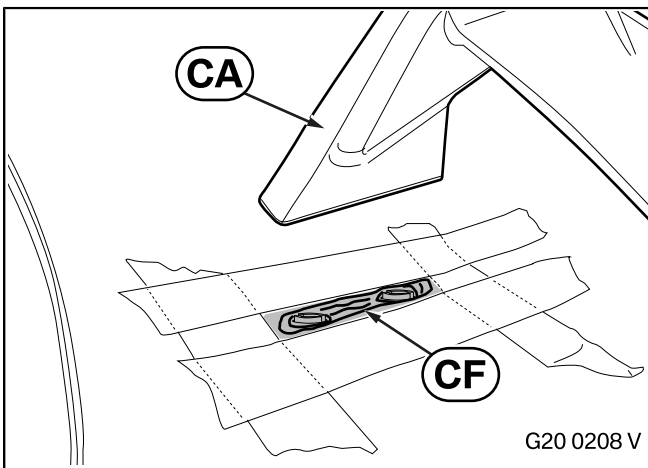

Apply two beads of the liquid adhesive **CF** around the prepared surfaces of the boot lid external skin and several more to the inside area of the surface. Apply generous quantities around the holes.

### 13. Carbon throughflow rear spoiler installation

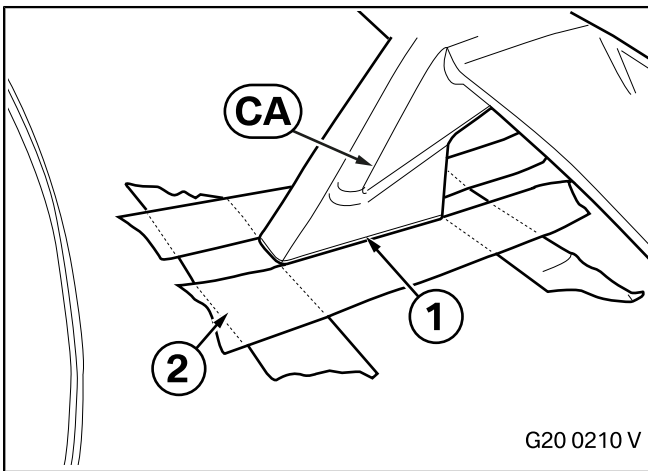
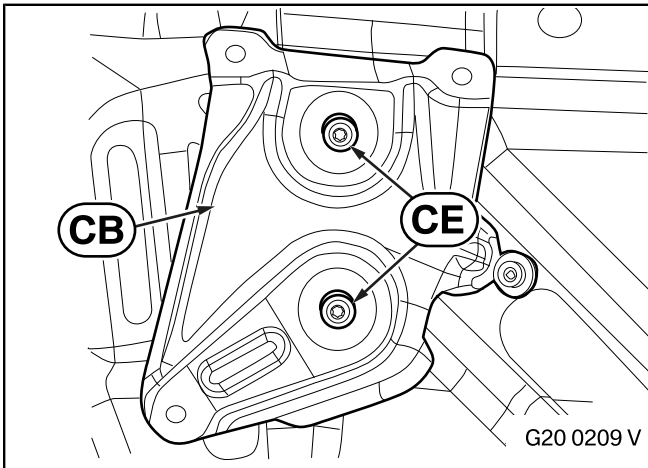

▶ This installation step must be carried out by three people.

Install the boot lid spoiler **CA**, with two people positioning it from the outside and one person tightening the screws for the boot lid spoiler **CA** from the inside. ◀

Position the boot lid spoiler **CA** on the boot lid with two people. Secure the M6x25 screws **CE** from the inside.

The tightening torque for the screws **CE** is **10 Nm**.

Remove excess liquid adhesive immediately using suitable equipment and dab the joint (1) with suitable equipment (for example cotton buds).

Remove the adhesive tapes (2) on the boot lid.

Then fit the interior trim.

▶ Leave the car to stand for 24 hours and refer to the instructions on page 2. ◀

## 14. Black high gloss side sill add-on section installation

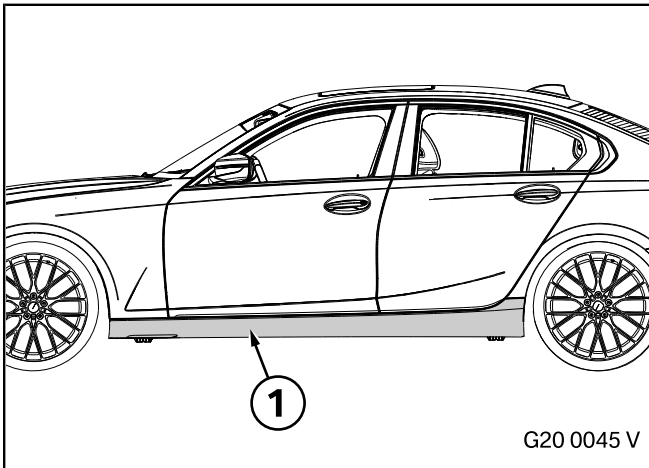

 The bonding surfaces must be completely dry, clean, and free from wax or grease. ◀

Clean the surface (1).

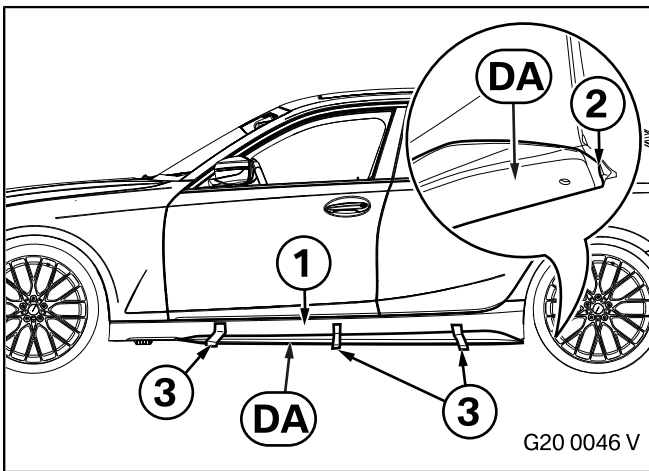

Position the side sill add-on section **DA** on the side sill (1). The rear contour (2) of the side sill add-on section **DA** must be flush with the rear contour of the side sill (1). Secure the side sill add-on section **DA** using suitable adhesive tape (3).

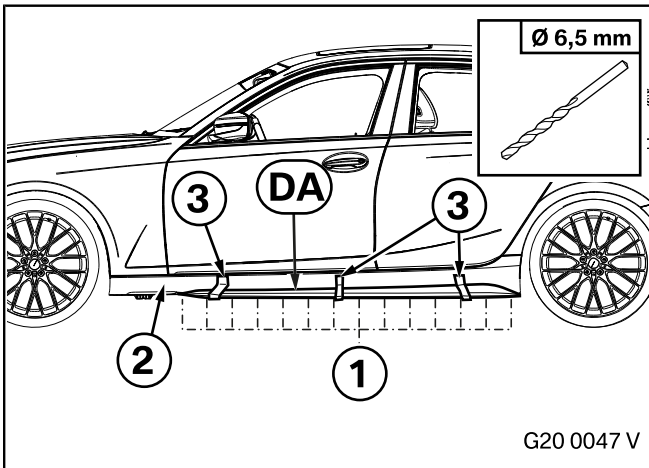

Drill the 14 holes (1) from the side sill add-on section **DA** with a diameter of **6.5 mm** in the side sill (2). Remove the adhesive tape (3) and the side sill add-on section **DA**.

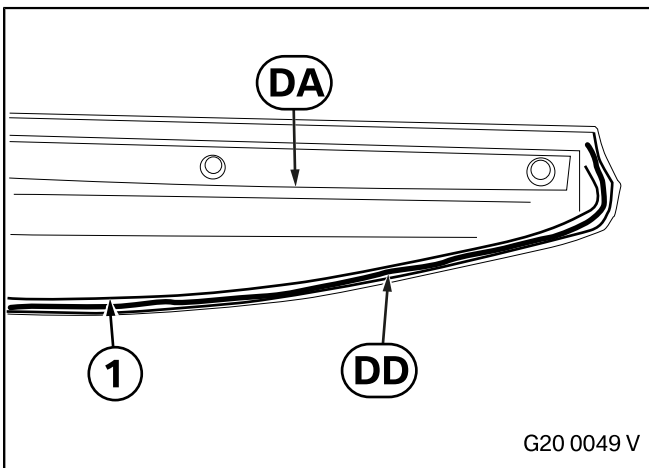

 Follow the instructions for use for the liquid adhesive **DD**. Apply the liquid adhesive **DD** to the side sill add-on section **DA** only on the external side of the car at the installation position. ◀

Clean the flange (1) on the side sill add-on section **DA** using the cleaner **DC**.

Apply a bead of liquid adhesive **DD** to the flange (1).

## 14. Black high gloss side sill add-on section installation

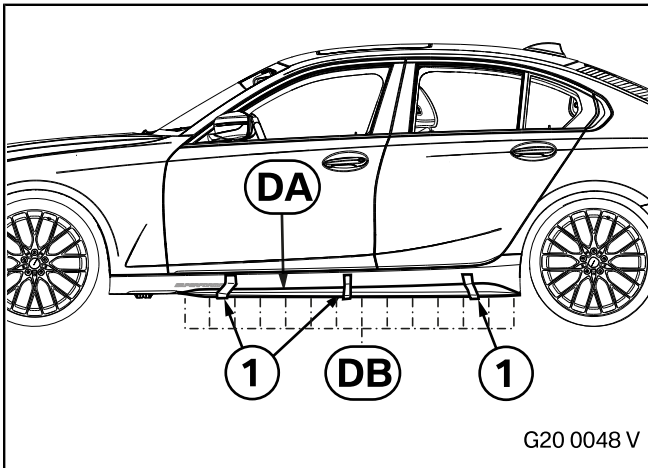

- ▶ If the Frozen Black foil wrap (**Part No. 51 14 2 458 194**) is not fitted, the M Performance logo sticker (**Part No. 51 14 2 461 811, to be ordered separately**) must also be fitted. ◀

Position the side sill add-on section **DA** and secure it with the rivets **DB**.

Apply suitable adhesive tape (1).

- ▶ Do not apply the adhesive tape (1) with excessive tension to prevent stress in the side sill add-on section **DA**.

Remove any excess liquid adhesive immediately.

Leave the car to stand for 24 hours and refer to the instructions on page 2. ◀

## 15. Carbon rear diffuser installation

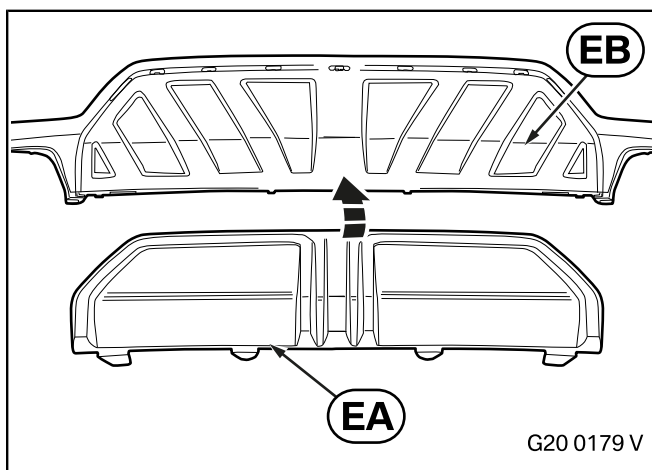

▶ The figures show the MPA version. Install the MSP version using the same procedure. ◀

Insert the clips for the carbon rear diffuser **EA**, starting from the centre and working towards the sides so that they audibly click into the black high gloss rear bumper trim **EB**.

Then install the black high gloss rear bumper trim **EB** on the car as described in ISTA/AIR.

## 16. Black high gloss tail fin installation

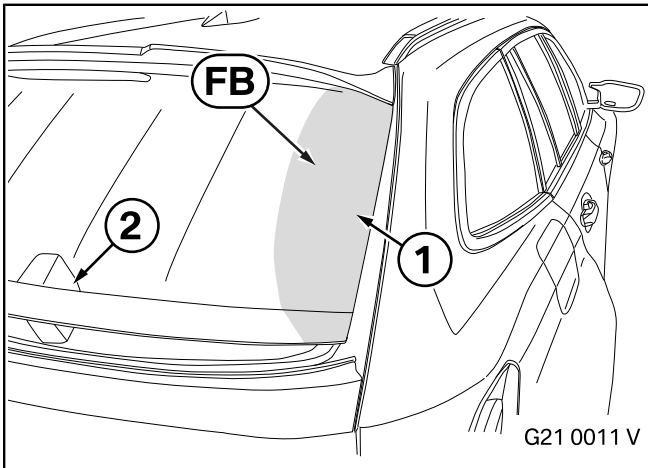

- ☐ The bonding surfaces must be completely dry, clean, and free from wax or grease. ◀

Clean the rear window at the sides (1) using cleaner R1 **FB**.

To gain easier access to the edge of the rear window, open the rear window separately and insert a suitable object into it (2).

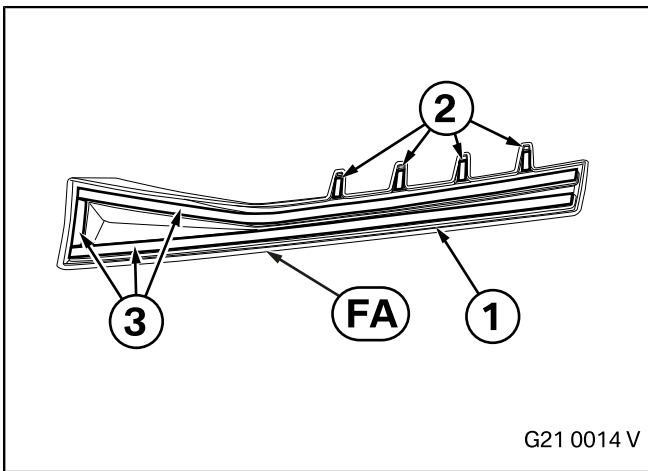

Clean the rear of the right tail fin **FA** using primer **FD**.

- ☐ Wait until the drying time has elapsed. ◀

Completely remove the red backing foils (3) on the adhesive tapes on the rear of the right tail fin **FA**.

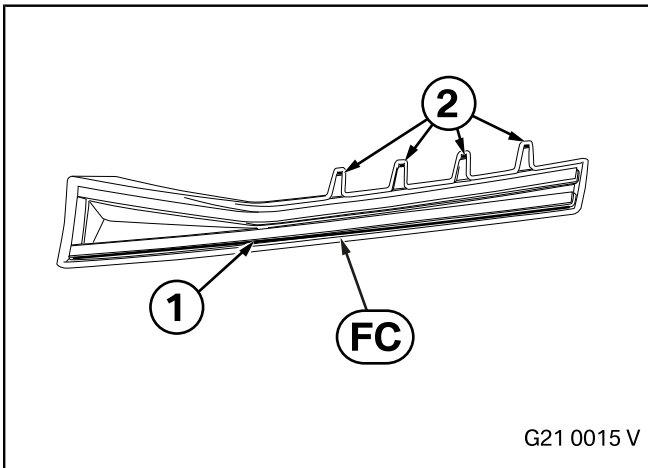

Apply the liquid adhesive **FC** to the recess (1) in a straight line. Apply a dot of liquid adhesive **FC** to end of the each finger (2).

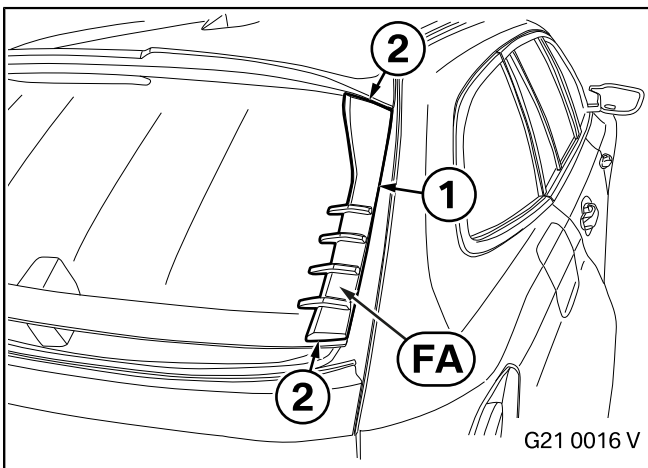

Align the right tail fin **FA** on the outer edge (1), centre it at the top and bottom (2), place it on the rear window and press it into position.

- ☐ Removing any surplus liquid adhesive **FC** immediately using a suitable tool (for example a scraper or the like). ◀

## 16. Black high gloss tail fin installation

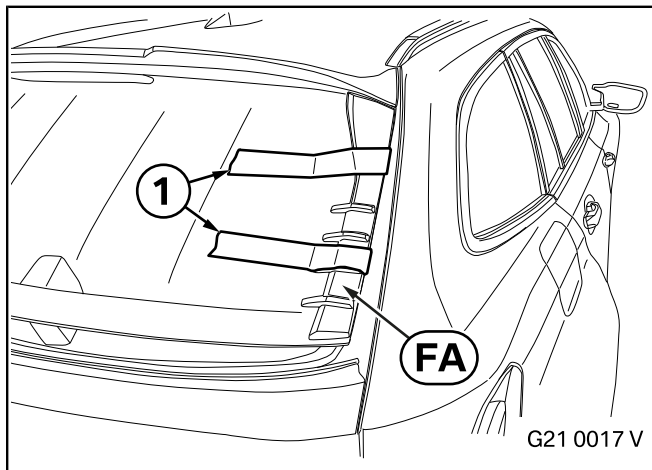

Press down the right tail fin **FA** using suitable adhesive tape (1) and secure it to prevent it from slipping.

Repeat the process on the left-hand side of the car.

 Leave the car to stand for 24 hours and refer to the instructions on page 2. ◀

## 17. Towing strap installation

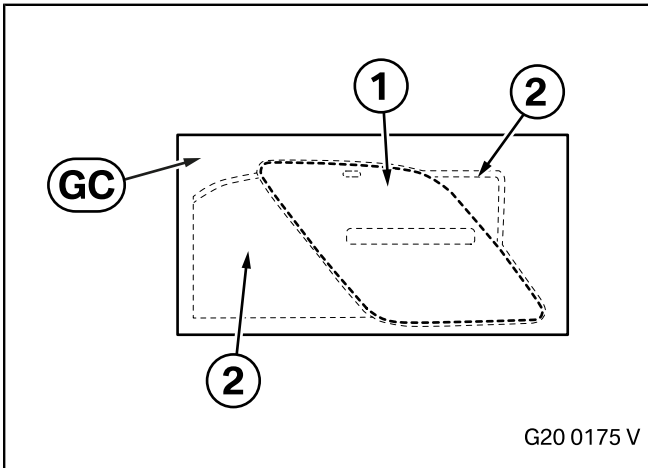

Select the appropriate part from the front/rear template **GC** for the front cover or rear cover and cut out the contour.

The rhombus (1) is for the rear cover on the car.

The area (2) as for the front cover on the car.

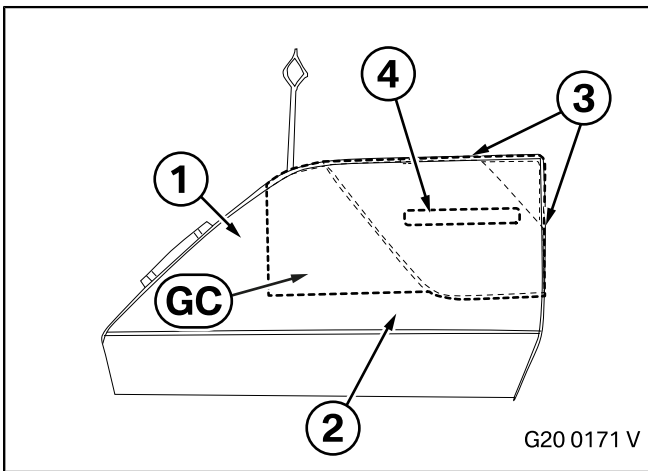

▣ The installation work on the front of the car is described as an example. Use the same procedure at the rear of the car. The bonding surfaces must be completely dry, clean, and free from wax or grease. ◀

Remove the right trim (1) as described in ISTA/AIR. Clean the surface (2) with suitable products. Align the template **GC** flush with the edges (3) and affix it.

Cut out the opening (4) with suitable products. Remove the template **GC** and deburr the edges.

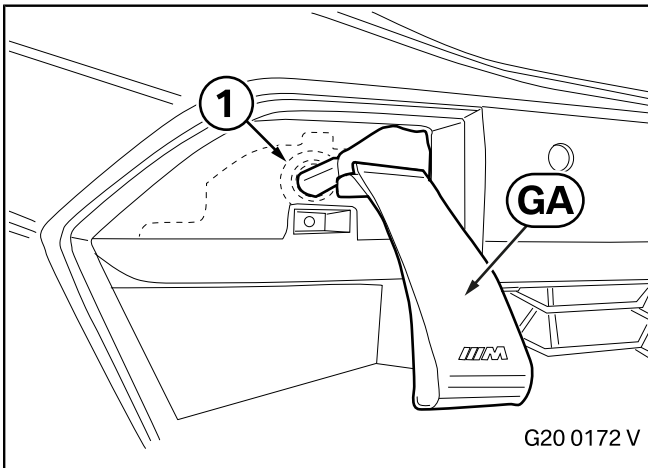

Screw the towing strap **GA** into the thread (1) (not visible).

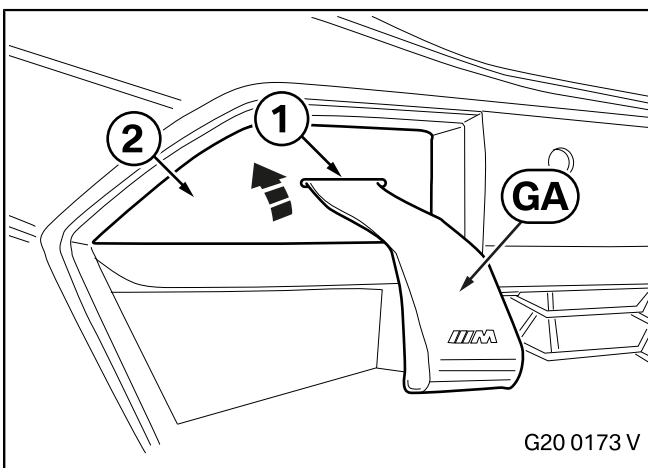

Thread the towing strap **GA** through the opening (1) and clip the right trim (2) into position as described in ISTA/AIR.

## 17. Towing strap installation

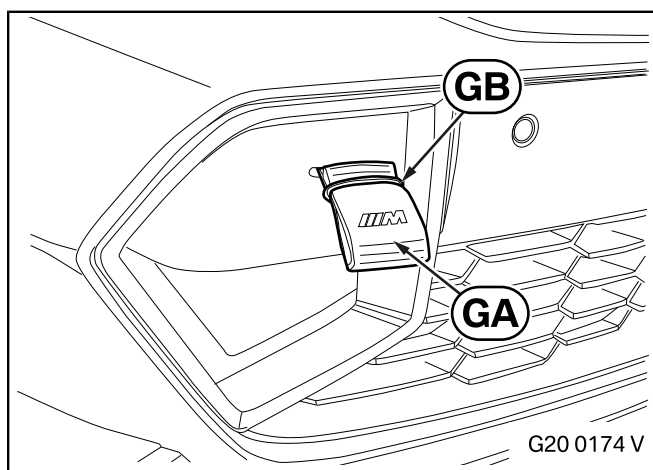

Fold up the towing strap **GA** and secure it with the rubber band **GB**.

## 18. Concluding work and coding

The retrofit system requires programming/coding for all cars if the carbon rear diffuser retrofit kit is installed.

- Connect the battery
- Connect the battery charger to the car
- Connect the car to the ISTA workshop system
- Open the ISTA/P car programming facility
- If using ISTA/P, please refer to the instructions provided in the ISTA/P application documentation
- Retrofit customer service word for carbon rear diffuser: Select "DSMO" via the – **Retrofits** – path and work through the action plan
- If necessary, carry out a vehicle test using the ISTA system, and note, or work through, any errors that have been recorded
- Conduct a function test
- Re-assemble the car
- Give the customer the customer information